

44-Pin Micromite

User Manual Addendum

Geoff Graham

For updates to this manual and more details on MMBasic
go to <http://mmbasic.com>
or <http://geoffg.net/micromite.html>

Copyright 2011 - 2014 Geoff Graham

This manual is licensed under a
Creative Commons Attribution-NonCommercial-ShareAlike 3.0 Australia
(CC BY-NC-SA 3.0)

44 Pin Microcontrollers

The best chip to use is the PIC32MX150F128D-50I/PT which is guaranteed to run up to 48MHz and costs \$3.72. Similar to the 28 pin package there are versions rated at 40MHz and versions that support USB (with the latter you loose access to two I/O pins which are reserved for USB functions (pins 10 and 42)).

The following is a summary of the recommended chips for the Micromite in a 44 pin package:

PIC32MX150F128D-50I/PT	Guaranteed to run at 48MHz.
PIC32MX150F128DI/PT	Should run at 48MHz despite its 40MHz spec.

The following will also run the firmware

PIC32MX250F128D-50I/PT	Guaranteed to run at 48MHz but only supports 31 I/O pins
PIC32MX250F128DI/PT	40MHz spec but should run at 48MHz - only supports 31 I/O pins

These chips are in a TQFP surface mount package which has a lead pitch of 0.8mm. This is reasonably easy to solder and the chip can be mounted on a carrier board which brings the pins out on an easy to use 0.1 inch grid.

The firmware file used for the 44 pin chips is different from the 28 pin firmware but, once the firmware is loaded, MMBasic will work the same in either chip. The only difference is that this chip has an extra 14 I/O pins that are accessible from within MMBasic.

The power requirements and the need for a 47µF capacitor are exactly the same as for the 28 pin chip.

Loading the Micromite firmware is done via a PIC32 programmer using the following circuit.

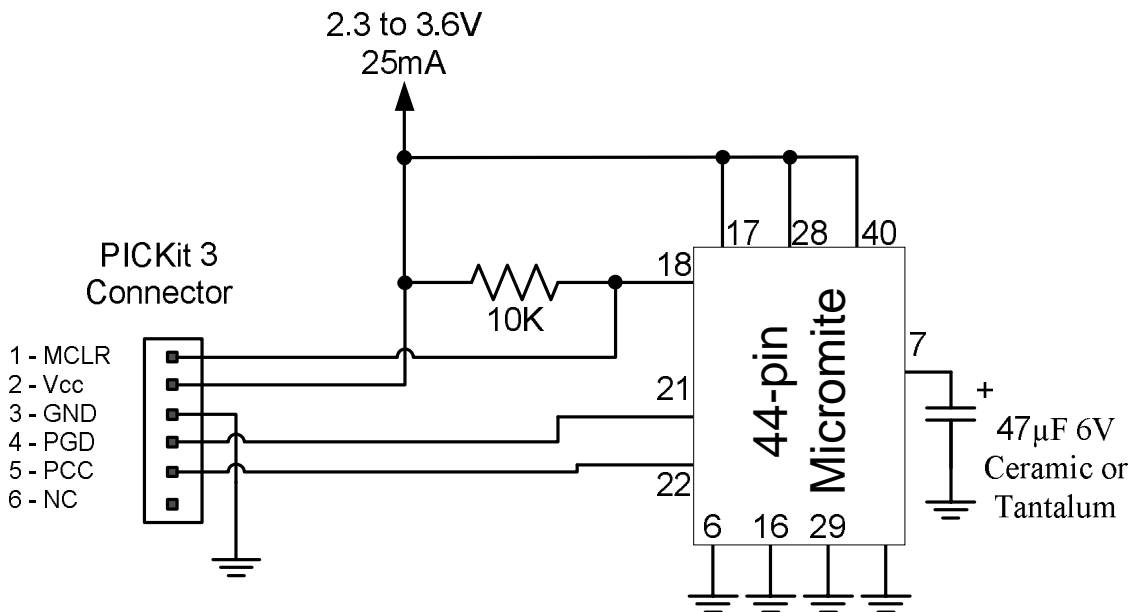

44 Pin Micromite Connections

The following diagram shows the possible functions of each I/O pin on the 44 pin Micromite.

Note that the physical pins on the chip and the pin numbers used in MMBasic are the same. This means that eleven pins are not available in MMBasic (these pins are highlighted in grey).

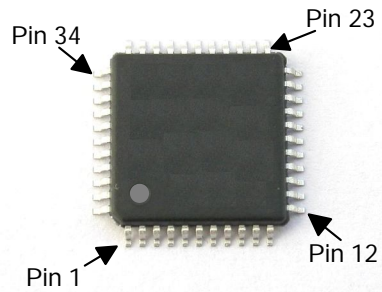

	Pin	Pin	
ANALOG DIGITAL PWM 1C	23	22	PWM 1B DIGITAL ANALOG
ANALOG DIGITAL COM1: ENABLE	24	21	PWM 1A DIGITAL ANALOG
ANALOG DIGITAL	25	20	SPI OUT (MOSI) DIGITAL ANALOG
ANALOG DIGITAL	26	19	DIGITAL ANALOG
ANALOG DIGITAL	27	18	<i>RESET Wired to +V directly or via 10K resist</i>
<i>POWER (+2.3 to +3.6V)</i>	28	17	<i>ANALOG POWER (+2.3 to +3.6V)</i>
<i>GROUND</i>	29	16	<i>ANALOG GROUND</i>
DIGITAL COM2: TRANSMIT	30	15	PWM 2A DIGITAL ANALOG
DIGITAL COM2: RECEIVE	31	14	SPI CLOCK DIGITAL ANALOG
DIGITAL 5V	32	13	5V DIGITAL
<i>CONSOLE Tx (DATA OUT)</i>	33	12	5V DIGITAL
<i>CONSOLE Rx (DATA IN)</i>	34	11	PWM 2B DIGITAL ANALOG
DIGITAL 5V	35	10	INT DIGITAL ANALOG
DIGITAL	36	9	COM1: RECEIVE 5V INT DIGITAL
DIGITAL 5V	37	8	COM1: TRANSMIT 5V INT DIGITAL
DIGITAL 5V	38	7	<i>47µF TANT CAPACITOR (+)</i>
<i>GROUND</i>	39	6	<i>GROUND</i>
<i>POWER (+2.3 to +3.6V)</i>	40	5	5V INT DIGITAL
DIGITAL 5V SPI IN (MISO)	41	4	5V INT DIGITAL
DIGITAL 5V COUNT	42	3	5V INT DIGITAL
DIGITAL 5V COUNT WAKEUP IR	43	2	5V INT DIGITAL
DIGITAL 5V COUNT I ² C CLOCK	44	1	I2C DATA COUNT 5V INT DIGITAL

The notation is as follows (the mnemonic in brackets is the mode used in the SETPIN command):

ANALOG	These pins can be used to measure voltage (AIN).
DIGITAL	Can be used for digital I/O such as digital input (DIN), digital output (DOUT) and open collector output (OOUT).
INT	Can be used to generate an interrupt (INTH, INTL and INTB).
COUNT	Can be used to measure frequency (FIN), period (PIN) or counting (CIN).
5V	These pins can be connected to 5V circuits. All other I/O pins are strictly 3.3V maximum.
COM <i>xxx</i>	These are used for serial communications (see Appendix A)
I ² C <i>xxx</i>	These are used for I ² C communications (see Appendix B)
SPI <i>xxx</i>	If SPI is enabled these pins will be used for SPI I/O (see Appendix D)
PWM <i>xxx</i>	PWM or SERVO output (see the PWM and SERVO commands)
IR	This can be used to receive signals from an infrared remote control (see the IR command)
WAKEUP	This pin can be used to wake the CPU from a sleep (see the CPU SLEEP command).

Pins 16 and 17 are the ground and power for analog measurements. Normally they are connected to the general ground and power (pins 29 and 28) but if you require noise free and accurate analog readings you should make sure that the power on pin 17 is regulated to 3.3V and well filtered. Also your analog inputs should be referenced to pin 16 (the analog ground).

Within MMBasic the SETPIN command is used to set the function of an I/O pin for general I/O. The PIN command or function is then used to interact with the pin. For example, this will print the voltage on pin 10:

```
SETPIN 10, AIN
PRINT "The voltage is" PIN(10) "V"
```

This voltage reading is referenced to pin 17 and assumes that the supply voltage on this pin is exactly 3.3V. You will need to scale the readings in your BASIC program if you use a supply voltage other than this.